

OK to fabricate  
 - TSUC winter  
 Production  
 manager

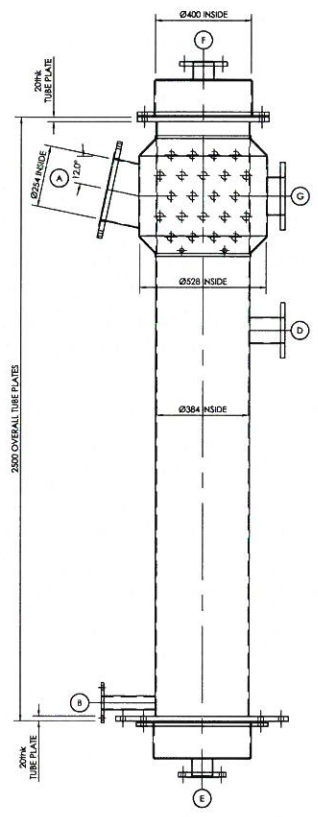

ELEVATION VIEW SEE PLAN VIEW FOR TRUE NOZZLE ORIENTATIONS

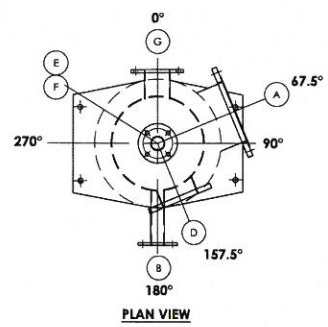

PLAN VIEW

CONDENSER	
SHELL	COPPER - BS EN 1652 CW024A R230
VAPOUR CHAMBER	COPPER - BS EN 1652 CW024A R230
VAPOUR INLET FLANGE > B	NAVAL BRASS - ASTM B171 M-F6 C46400
TUBE PLATES	NAVAL BRASS - ASTM B171 M-F6 C46400
TUBES	COPPER - BS EN 12449 CW024A R290
NOZZLE - NECK	COPPER - BS EN 1652 CW024A R230
NOZZLE - FLANGE	NAVAL BRASS - ASTM B171 M-F6 C46400
BOLTING / NUTS	CARBON ST. - ZINC PLATED METRIC SERIES
GASKETS	NOVIUS SUPRA - 3IRk
WATER BOX (1:1)	
SHELL	SI.SI. - ASTM A240 304 MIN.
WATER BOX - FLANGE	SI.SI. - ASTM A240 304 MIN.
NOZZLE - NECK	SI.SI. - ASTM A312 TP 304 MIN.
NOZZLE - FLANGE	SI.SI. - ASTM A182 F 304 MIN.
BOLTING / NUTS	CARBON ST. - ZINC PLATED METRIC SERIES
GASKETS - WATERBOX	EPDM - 6IRk

- GENERAL NOTES**
1. ALL SIZES ARE IN mm U.O.N.
  2. ALL SIZES ARE IN ACCORDANCE WITH FORSYTHS FABRICATION TOLERANCE DRAWING AFSD-01.
  3. ELEVATION VIEWS ARE REPRESENTATIVE ONLY. REFER TO THE PLAN VIEW FOR TRUE ORIENTATIONS.
  4. SEE DRAWING C3926-103 Rev.03 FOR LAYOUT.

- FABRICATION NOTES**
1. COPPER WELDS TO BE POWER/HAND HAMMERED SMOOTH AND FLUSH.
  2. ALL SIZES TO BE THICKS WELDED AS REQUIRED.
  3. ALL FLANGE BOLT HOLES TO BE OFF-CENTRES TO MAIN VESSEL CENTRE LINES.
  4. ALL BURRS & SHARP EDGES TO BE REMOVED.
- OVERALL HEIGHTS TO BE CHECKED DURING FABRICATION & ASSEMBLY.

REF.	NPS	DESCRIPTION	CLASS	TYPE	BODY	REMARKS
A	10"	VAPOUR INLET	ASA150#	PLATE	10SWG	C46400
B	2"	SPIRIT TAIL PIPE	ASA150#	PLATE	10SWG	C46400
D	4"	SEAL POT SUPPORT	ASA150#	PLATE	10SWG	C46400
E	2"	WATER INLET	ASA150#	SCRF	SCH10	
F	2"	WATER OUTLET	ASA150#	SCRF	SCH10	
G	4"	COLUMN INLET	ASA150#	PLATE	10SWG	C46400

REV	DATE	DESCRIPTION	DRN	APP
01	01OCT19	FIRST ISSUE	SM	HB

**Forsyths** ROTHES, MORAY  
 AB38 7AD  
 SCOTLAND  
 990  
 TEL: +44 (0)1340 831 787; FAX: +44 (0)1340 831 558; E-MAIL: enquiries@forsyths.com  
 CLIENT:  
 HIGH WEST DISTILLERY  
 PARK CITY, UTAH, U.S.A.  
 TITLE:  
 WASH CONDENSER FOR POT No.2  
 GENERAL ARRANGEMENT